

MultiCam[®]

CNC Cutting Solutions

MultiCam[®] Classic Series CNC Router Feature and Specification Guide

Classic CNC ROUTERS

High-Performance CNC Routing at an Entry-Level Price

MultiCam[®] accepted the industry challenge to build a rigid, reliable CNC cutting machine platform with excellent performance at an entry-level price. Over 20 years of cutting-edge, industry-leading design experience created the MultiCam Classic Series Router. This machine offers a price/performance breakthrough in CNC router design.

The MultiCam Classic Series Router is the perfect solution for applications requiring value, performance and price in a CNC router.



MultiCam, Inc.
1025 West Royal Lane
DFW Airport, TX 75261
972-929-4070 • Fax: 972-929-4071
www.multicam.com • sales@multicam.com

All specifications subject to change.
© 2009 MultiCam, Inc. All Rights Reserved.

Ideal for Cutting:

- ***Plastics***
- ***Non-Ferrous Metals***
- ***Composite Materials***
- ***Wood***

And More

Innovation. Quality. Performance.

Classic Series Specifications

No machine in its class offers more standard features than the innovative and versatile MultiCam Classic Series Router.

- High-frequency 3-hp spindle
- EZ Control® user-friendly operator interface
- Automatic tool calibration
- High-speed three-axis motion controller
- Precision dual X-axis drives
- Cast dust collector shroud/pressure foot
- 25-mm linear bearing rails for maximum stiffness



EZ Control®

MultiCam EZ Control® is one of the most powerful yet easy-to-use motion-control systems available on machine tools today. No wonder MultiCam named its motion system EZ Control!

- Hand-held operator interface with graphic icons
- 12-MB memory with unlimited file-size transfer capabilities
- Multiple home positions
- Automatic Z surfacing
- Electronic depth safety system
- Proximity restart
- Tool compensation
- Cut speed override
- Spindle rpm override
- Standard Ethernet TCP/IP connection



Spindle

Each Classic Series Router comes standard with a 3-hp, 24,000-rpm spindle and cast-aluminum dust foot. The spindle features an ER-20 collet which will handle tools up to 0.5" in diameter.

Working Surfaces

The aluminum T-slot vacuum table provides a low-cost working surface to hold parts. Or order optional phenolic grid tops with or without vacuum zoning. Choose from a selection of MultiCam vacuum pump options.



Classic Series Specifications

Base Frame

MultiCam fabricates the frame using aerospace-grade aluminum extrusions with integrated bearing datums. The legs are manufactured from heavy-gauge sheet steel.



Gantry

MultiCam engineered the gantry tube from aircraft-quality aluminum extrusion for maximum stiffness. Its 10-mm wall thickness ensures rigidity. References for the precision linear bearings are extruded in the design and have excellent parallelism.

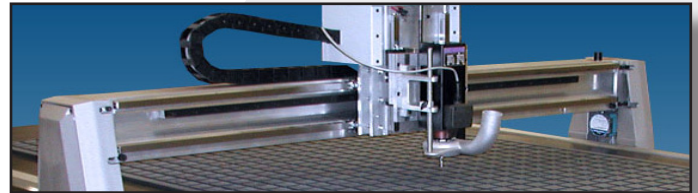

Gantry Supports

Cast-aluminum gantry supports machined on a four-axis horizontal machining center guarantee perpendicularity and precision placement of linear bearings. Castings have inherent vibration-dampening characteristics and give very stiff support to the gantry tube.

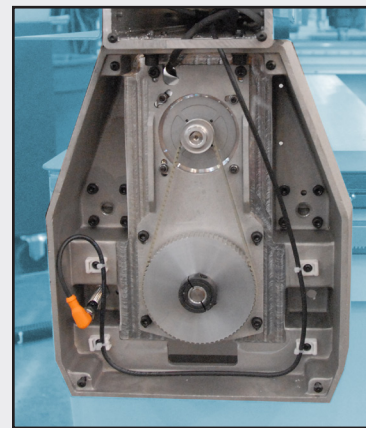

Linear Bearings

The 25-mm linear bearing profile rails with stainless spring steel strip covers are standard in the X, Y and Z axes.

- High rigidity and top-load capacities in all load directions
- Lowest possible noise level and best running characteristics
- High-torque load capacity
- Four bearing packs per axis
- 4000-pound load capacity per bearing



Classic Series Specifications

Z-Screw Assembly

The Classic Series utilizes a ½" diameter stainless steel lead screw. For high axial force loads, a precision mounting block with dual angular contact ball bearings holds it in place firmly. A brass lead screw nut carries the Z-axis load.

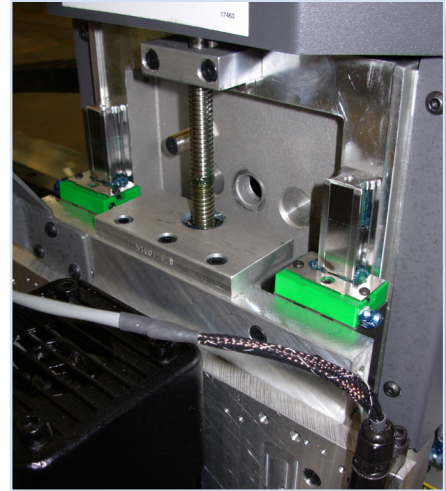

Drive Motor System

For the Classic Series, MultiCam selected extensively tested two-phase, digital, brushless, synchronous electric motors. Optimized inductance and resistance of the windings provide system smoothness. Integrated digital motor drives run these motors very efficiently.

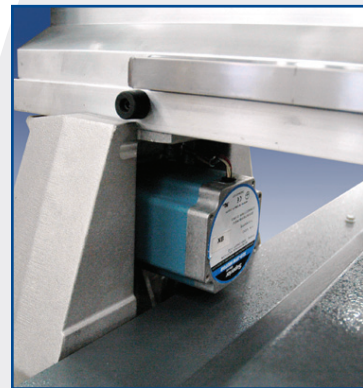

Drive Assembly

Transmissions on the X and Y axes based on a precision-machined aluminum casting feature steel cable urethane belt drives for smooth transmission of power. A dual bearing arbor with wide bearing separation supports output pinions for optimum stiffness.



Classic Series Specifications

Standard Features



Leveling Feet



Tool Box



Operation Manual

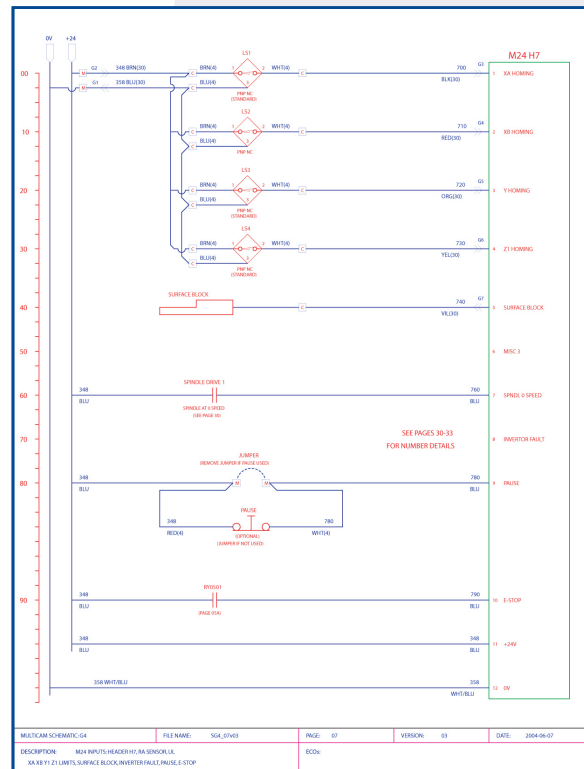

Electrical Schematics

Classic Series Specifications

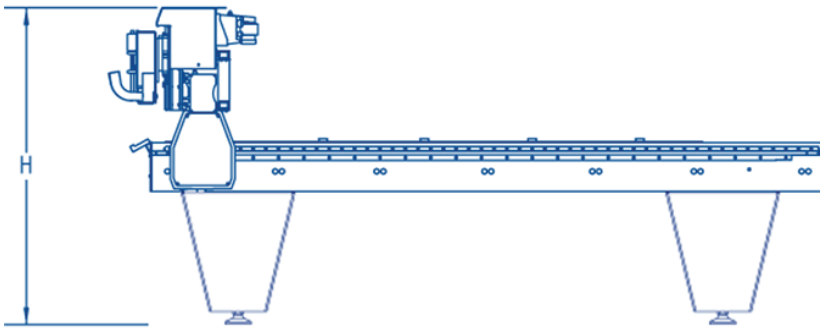
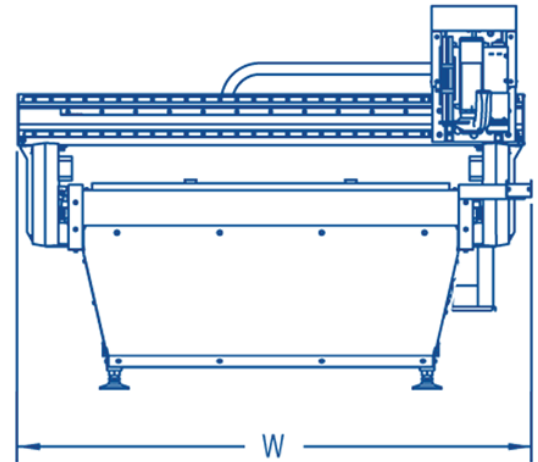
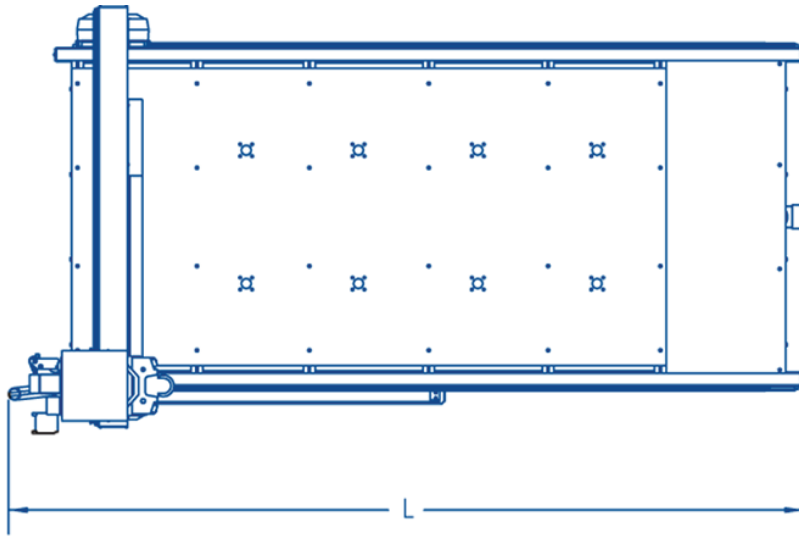

Classic Series Specifications

- Z-Axis Clearance: 4.5" (114 mm)
- Z-Axis Travel: 6" (152 mm)
- Repeatability: +/- 0.001" (0.0254 mm)
- Cutting Speed: 600 IPM (15.2 MPM)
- Rapid Traverse: 850 IPM (21.6 MPM)
- Drive System X and Y Axes: Rack and Pinion
- Drive System Z Axis: Lead Screw
- Standard Work Surface: Aluminum T-Plate Extrusion

Size Chart (Inches)

MODEL	L	W	H	WORKING AREA
C-101	80	71	54	50 x 50
C-103	132	71	54	50 x 100
C-204	156	81	54	60 x 120
C-304	156	101	54	84 x 120

Specifications subject to change.

Size Chart (Metric)

MODEL	L	W	H	WORKING AREA
C-101	2032	1803	1371	1270 x 1270
C-103	3353	1803	1371	1270 x 2540
C-204	3962	2057	1371	1524 x 3048
C-304	3962	2565	1371	2133 x 3048

